

ELEVAH[®]

E5 ES



98 cm



70 cm



ELEVAH[®] 5ES

Max. working height		4,9 m
Max capacity		150 kg
Number of people		1
Use		Internal
A	Closed machine height	1730 mm
B	Minimum platform height	289 mm
C	Maximum platform height	2916 mm
D	Base overall dimensions	980 mm
E		700 mm
G	Cage dimensions	1000 mm
F		690 mm
Machine weight		720 kg
Drive wheels dimension		Ø 186 x 60 mm
Swivel wheels dimensions		Ø 150 x 40 mm
Adjustment/extraction		Manual
J	Stroke	600 mm
Minimum extension		1000 mm
Maximum extension		1600 mm
Power supply		24 V
Batteries		2 Trojan Lead-Acid 12V 105 Ah
Battery charger		115V – 230V 50/60HZ
M	Maximum climbing ability	15%
Climbing ability at height		2,5%
Internal turning radius		0
External turning radius		1080 mm
Max. speed (rising – descending)		0,2 m/s
Maximum shifting speed		5,5 km/h
Maximum shifting speed at height		1 km/h
N	Maximum pressure for wheel at full load**	3 kN
Work cycles (with fresh batteries) ***		100

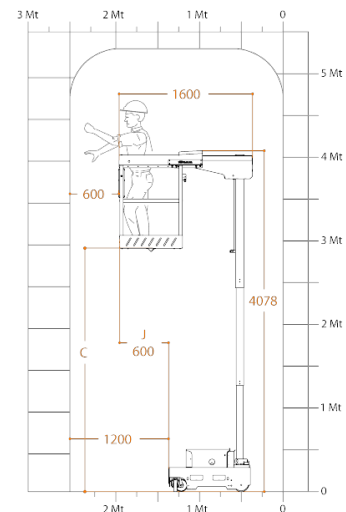
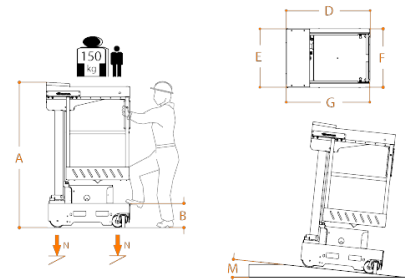

* There is an intermediate step.

** Maximum pressure whereas the weight of the platform plus the maximum load on the basket are completely distributed on one side of the platform (totally asymmetric load).

*** By work cycle we mean a self-propelled movement of 20 m with a full ascent to and descent from the maximum height and with adjustment of the loading platform.



Compliant with **EN280** rule.
Approved for indoor use or outdoor use in the absence of wind.